

■ General Description

The AME8510/8520/8530 family allows the user to customize the CPU monitoring function without any external components. The user has a large choice of reset voltage thresholds and output driver configurations, all of which are preset at the factory. Each wafer is trimmed to the customer's specifications.

These circuits will ignore fast negative going transients on V_{IN} . The state of the reset output is guaranteed to be correct down to 1V.

After V_{IN} crosses above a factory preset threshold, the AME8510/8520/8530 assert a reset signal. After a pre-determined time (the "reset" interval) the reset is deasserted. If V_{IN} ever drops below the threshold voltage a reset is asserted immediately. In addition to a supply monitoring function the AME8510/8520 also monitor transitions at the watch dog input (WDI). If a logic transition does not occur at the WDI pin within a certain time interval (the "watchdog" interval) then a reset is asserted. The reset deasserts after the reset interval, as explained earlier.

The AME8510/8530 can both assert a reset manually by pulling the MRB input to ground.

Space saving SOT-25/TSOT-25 packages and micropower quiescent current make this family a natural for portable battery powered equipment.

■ Features

- Small Packages: SOT-25/TSOT-25
- 7 Voltage Threshold Options
- Tight Voltage Threshold Tolerance --- $\pm 1.50\%$
- 12 Output Driver Configuration Options
- Wide Temperature Range ----- -40°C to $+85^{\circ}\text{C}$
- Low Quiescent Current $< 3.0\mu\text{A}$
- 3 Bonding Options
- All AME' s Lead Free Products Meet RoHS Standards

■ Applications

- Motherboards
- Computer peripherals
- Portable electronics
- Applications using CPUs
- Consumer electronics

■ Pin Configuration

**SOT-25/TSOT-25
Top View**

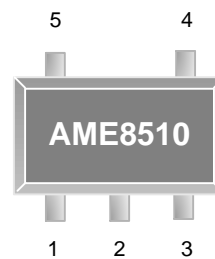

AME8510

1. Reset/ResetB
2. GND
3. MRB
4. WDI
5. IN

* **Die Attach:**

Conductive Epoxy

**SOT-25/TSOT-25
Top View**

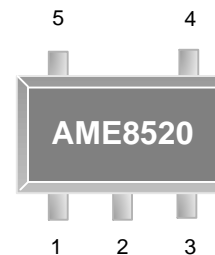

AME8520

1. Reset/ResetB
2. GND
3. ResetB/Reset
4. WDI
5. IN

* **Die Attach:**

Conductive Epoxy

**SOT-25/TSOT-25
Top View**

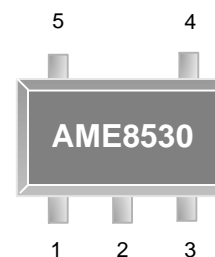

AME8530

1. Reset/ResetB
2. GND
3. ResetB/Reset/NC
4. MRB
5. IN

* **Die Attach:**

Conductive Epoxy

■ Pin Description

Pin Number			Pin Name	Pin Description
AME8510	AME8520	AME8530		
1	1	1	RESET/ RESETB	This pin may be either RESET or RESETB. RESETB is active low. In the case of the AME8520 and AME8530 this pin will always be the opposite polarity from pin 3. This pin can be push/pull or open drain.
2	2	2	GND	Ground
N/A	3	3	RESET/ RESETB	This pin may be either RESETB or RESET. RESET is active high. In the case of the AME8520 and AME8530 this pin will always be the opposite polarity from pin 1. This pin can be either push/pull or open drain.
3	N/A	4	MRB	Manual Reset. Active low. Pulling this pin low forces a reset. After a low to high transition reset remains asserted for exactly one reset timeout period. This pin is internally pulled high. If this function is unused then float this pin or tie it to V_{IN} .
4	4	N/A	WDI	Watch Dog Input. Any transition on this pin will reset the watch dog timer. If this pin remains high or low for longer than the watch dog interval then a reset is asserted. Float or tristate this pin to disable the watch dog feature.
5	5	5	IN	Positive power supply. A reset is asserted after this voltage drops below a predetermined level. After V_{IN} rises above that level reset remains asserted until the end of the reset timeout period.



AME8510 / 8520 / 8530

Micropower mP Watch Dog Timer

Ordering Information

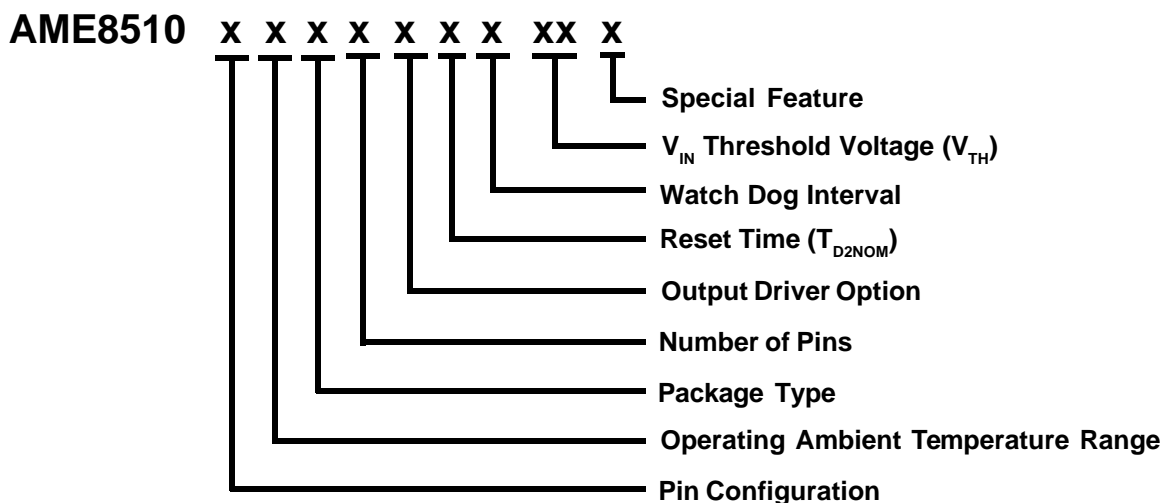

Pin Configuration	Operating Ambient Temperature Range	Package Type	Number of Pins	Output Driver Option	Reset Time (T _{D2NOM})	Watch Dog Interval	V _{IN} Threshold Voltage (V _{TH})	Special Feature
A: 1. Reset/ResetB <small>(SOT-25)</small> <small>(TSOT-25)</small> 2. GND 3. MRB 4. WDI 5. IN	E: -40°C to +85°C	E: SOT-2X	V: 5	A: PIN1_RESETB/PP B: Pin1_RESETB/OD C: PIN1_RESET/PP D: Pin1_RESET/OD <small>(RESET = Active High)</small> <small>(RESETB = Active Low)</small> <small>(PP = Push pull out)</small> <small>(OD = Open drain output)</small>	D: 30ms E: 150ms F: 210ms	D: 1000 ms E: 1761 ms	22: V _{TH} = 2.19V 23: V _{TH} = 2.32V 26: V _{TH} = 2.63V 29: V _{TH} = 2.93V 31: V _{TH} = 3.08V 42: V _{TH} = 4.20V 44: V _{TH} = 4.38V 45: V _{TH} = 4.50V 46: V _{TH} = 4.63V	L: Low profile Y: Lead free & Low profile Z: Lead free

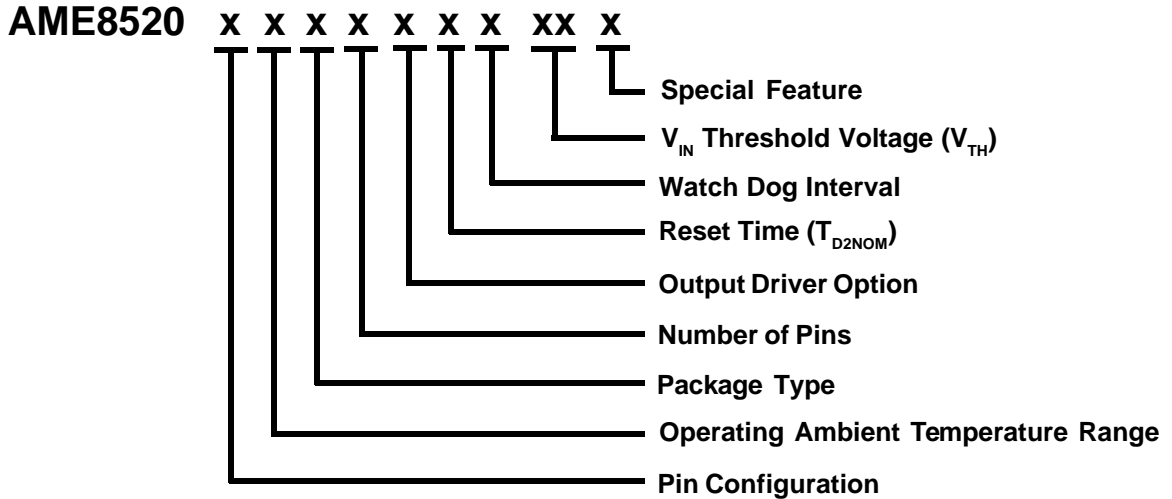
■ Ordering Information

Pin Configuration	Operating Ambient Temperature Range	Package Type	Number of Pins	Output Driver Option	Reset Time (T_{D2NOM})	Watch Dog Interval	V_{IN} Threshold Voltage (V_{TH})	Special Feature
A: 1. Reset/ (SOT-25) ResetB (TSOT-25) 2. GND 3. Reset/ ResetB 4. WDI 5. IN	E: -40°C to +85°C	E: SOT-2X	V: 5	E: PIN1_RESETB/PP PIN3_RESET/PP F: PIN1_RESETB/PP PIN3_RESET/OD G: PIN1_RESETB/OD PIN3_RESET/PP H: PIN1_RESETB/OD PIN3_RESET/OD I: PIN1_RESET/PP PIN3_RESETB/PP J: PIN1_RESET/PP PIN3_RESETB/OD K: PIN1_RESET/OD PIN3_RESETB/PP L: PIN1_RESET/OD PIN3_RESETB/OD	D: 30ms E: 150ms F: 210ms	E: 1761 ms	22: V_{TH} = 2.19V 23: V_{TH} = 2.32V 26: V_{TH} = 2.63V 29: V_{TH} = 2.93V 31: V_{TH} = 3.08V 42: V_{TH} = 4.20V 44: V_{TH} = 4.38V 45: V_{TH} = 4.50V 46: V_{TH} = 4.63V	L: Low profile Y: Lead free & Low profile Z: Lead free

(RESET = Active High)
 (RESETB = Active Low)
 (PP = Push pull out)
 (OD = Open drain output)



AME8510 / 8520 / 8530

Micropower mP Watch Dog Timer

Ordering Information

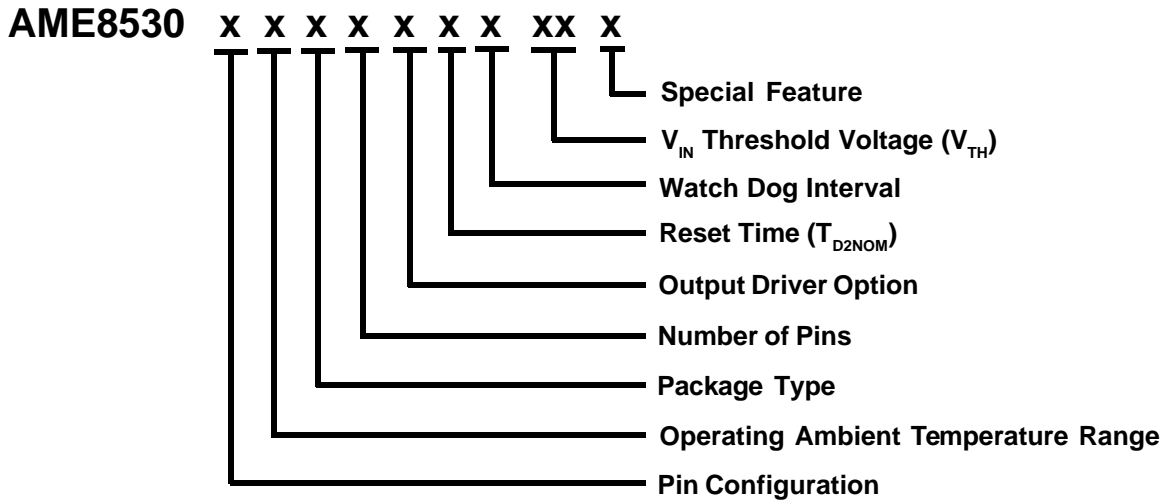

Pin Configuration	Operating Ambient Temperature Range	Package Type	Number of Pins	Output Driver Option	Reset Time (T _{D2NOM})	Watch Dog Interval	V _{IN} Threshold Voltage (V _{TH})	Special Feature
A: 1. Reset/ResetB (SOT-25) (TSOT-25) 2. GND 3. Reset/ResetB 4. MRB 5. IN	E: -40°C to +85°C	E: SOT-2X	V: 5	A: PIN1_RESETB/PP PIN3_NC B: PIN1_RESETB/OD PIN3_NC C: PIN1_RESET/PP PIN3_NC D: PIN1_RESET/OD PIN3_NC E: PIN1_RESETB/PP PIN3_RESET/PP F: PIN1_RESETB/PP PIN3_RESET/OD G: PIN1_RESETB/OD PIN3_RESET/PP H: PIN1_RESETB/OD PIN3_RESET/OD I: PIN1_RESET/PP PIN3_RESETB/PP J: PIN1_RESET/PP PIN3_RESETB/OD K: PIN1_RESET/OD PIN3_RESETB/PP L: PIN1_RESET/OD PIN3_RESETB/OD	D: 30ms E: 150ms F: 210ms	X: without WDI option	22: V _{TH} = 2.19V 23: V _{TH} = 2.32V 26: V _{TH} = 2.63V 29: V _{TH} = 2.93V 31: V _{TH} = 3.08V 42: V _{TH} = 4.20V 44: V _{TH} = 4.38V 45: V _{TH} = 4.50V 46: V _{TH} = 4.63V	L: Low profile Y: Lead free & Low profile Z: Lead free

(RESET = Active High)
 (RESETB = Active Low)
 (PP = Push pull out)
 (OD = Open drain output)



AME8510 / 8520 / 8530

Micropower mP Watch Dog Timer

■ Ordering Information

Part Number	Marking*	V _{TH} Voltage	Package	Operating Ambient Temperature Range
AME8510AEEVAFE22	AWYww	2.19V	SOT-25	- 40°C to +85°C
AME8510AEEVAFE22L	AWYww	2.19V	TSOT-25	- 40°C to +85°C
AME8510AEEVAFE22Y	AWYww	2.19V	TSOT-25	- 40°C to +85°C
AME8510AEEVAFE22Z	AWYww	2.19V	SOT-25	- 40°C to +85°C
AME8510AEEVAFE26	ATGww	2.63V	SOT-25	- 40°C to +85°C
AME8510AEEVAFE26L	ATGww	2.63V	TSOT-25	- 40°C to +85°C
AME8510AEEVAFE26Y	ATGww	2.63V	TSOT-25	- 40°C to +85°C
AME8510AEEVAFE26Z	ATGww	2.63V	SOT-25	- 40°C to +85°C
AME8510AEEVAFE29	ATXww	2.93V	SOT-25	- 40°C to +85°C
AME8510AEEVAFE29L	ATXww	2.93V	TSOT-25	- 40°C to +85°C
AME8510AEEVAFE29Y	ATXww	2.93V	TSOT-25	- 40°C to +85°C
AME8510AEEVAFE29Z	ATXww	2.93V	SOT-25	- 40°C to +85°C
AME8510AEEVAFE31	ASMww	3.08V	SOT-25	- 40°C to +85°C
AME8510AEEVAFE31L	ASMww	3.08V	TSOT-25	- 40°C to +85°C
AME8510AEEVAFE31Y	ASMww	3.08V	TSOT-25	- 40°C to +85°C
AME8510AEEVAFE31Z	ASMww	3.08V	SOT-25	- 40°C to +85°C
AME8510AEEVAFE46	BACww	4.63V	SOT-25	- 40°C to +85°C
AME8510AEEVAFE46L	BACww	4.63V	TSOT-25	- 40°C to +85°C
AME8510AEEVAFE46Y	BACww	4.63V	TSOT-25	- 40°C to +85°C
AME8510AEEVAFE46Z	BACww	4.63V	SOT-25	- 40°C to +85°C
AME8510AEEVBDD29	ARXww	2.93V	SOT-25	- 40°C to +85°C
AME8510AEEVBDD29L	ARXww	2.93V	TSOT-25	- 40°C to +85°C
AME8510AEEVBDD29Y	ARXww	2.93V	TSOT-25	- 40°C to +85°C
AME8510AEEVBDD29Z	ARXww	2.93V	SOT-25	- 40°C to +85°C
AME8510AEEVBFE23	BCWww	2.32V	SOT-25	- 40°C to +85°C
AME8510AEEVBFE23L	BCWww	2.32V	TSOT-25	- 40°C to +85°C
AME8510AEEVBFE23Y	BCWww	2.32V	TSOT-25	- 40°C to +85°C
AME8510AEEVBFE23Z	BCWww	2.32V	SOT-25	- 40°C to +85°C
AME8510AEEVBFE26Z	BTNww	2.63V	SOT-25	- 40°C to +85°C
AME8510AEEVBFE29Z	BTLww	2.93V	SOT-25	- 40°C to +85°C



AME8510 / 8520 / 8530

Micropower mP Watch Dog Timer

■ Ordering Information (contd.)

Part Number	Marking*	V _{TH} Voltage	Package	Operating Ambient Temperature Range
AME8510AEEVBFE46	BCXww	4.63V	SOT-25	- 40°C to +85°C
AME8510AEEVBFE46L	BCXww	4.63V	TSOT-25	- 40°C to +85°C
AME8510AEEVBFE46Y	BCXww	4.63V	TSOT-25	- 40°C to +85°C
AME8510AEEVBFE46Z	BCXww	4.63V	SOT-25	- 40°C to +85°C
AME8510AEEVEFE31	ATUww	3.08V	SOT-25	- 40°C to +85°C
AME8510AEEVEFE31L	ATUww	3.08V	TSOT-25	- 40°C to +85°C
AME8510AEEVEFE31Y	ATUww	3.08V	TSOT-25	- 40°C to +85°C
AME8510AEEVEFE31Z	ATUww	3.08V	SOT-25	- 40°C to +85°C
AME8520AEEVEED46	BDAww	4.63V	SOT-25	- 40°C to +85°C
AME8520AEEVEED46L	BDAww	4.63V	TSOT-25	- 40°C to +85°C
AME8520AEEVEED46Y	BDAww	4.63V	TSOT-25	- 40°C to +85°C
AME8520AEEVEED46Z	BDAww	4.63V	SOT-25	- 40°C to +85°C
AME8520AEEVEFE22	AWSww	2.19V	SOT-25	- 40°C to +85°C
AME8520AEEVEFE22L	AWSww	2.19V	TSOT-25	- 40°C to +85°C
AME8520AEEVEFE22Y	AWSww	2.19V	TSOT-25	- 40°C to +85°C
AME8520AEEVEFE22Z	AWSww	2.19V	SOT-25	- 40°C to +85°C
AME8520AEEVEFE26	ATCww	2.63V	SOT-25	- 40°C to +85°C
AME8520AEEVEFE26L	ATCww	2.63V	TSOT-25	- 40°C to +85°C
AME8520AEEVEFE26Y	ATCww	2.63V	TSOT-25	- 40°C to +85°C
AME8520AEEVEFE26Z	ATCww	2.63V	SOT-25	- 40°C to +85°C
AME8520AEEVEFE29	ATVww	2.93V	SOT-25	- 40°C to +85°C
AME8520AEEVEFE29L	ATVww	2.93V	TSOT-25	- 40°C to +85°C
AME8520AEEVEFE29Y	ATVww	2.93V	TSOT-25	- 40°C to +85°C
AME8520AEEVEFE29Z	ATVww	2.93V	SOT-25	- 40°C to +85°C
AME8520AEEVEFE31	ATLww	3.08V	SOT-25	- 40°C to +85°C
AME8520AEEVEFE31L	ATLww	3.08V	TSOT-25	- 40°C to +85°C
AME8520AEEVEFE31Y	ATLww	3.08V	TSOT-25	- 40°C to +85°C
AME8520AEEVEFE31Z	ATLww	3.08V	SOT-25	- 40°C to +85°C



AME8510 / 8520 / 8530

Micropower mP Watch Dog Timer

■ Ordering Information (contd.)

Part Number	Marking*	V _{TH} Voltage	Package	Operating Ambient Temperature Range
AME8520AEEVEFE42	ATK _{ww}	4.20V	SOT-25	- 40°C to +85°C
AME8520AEEVEFE42L	ATK _{ww}	4.20V	TSOT-25	- 40°C to +85°C
AME8520AEEVEFE42Y	ATK _{ww}	4.20V	TSOT-25	- 40°C to +85°C
AME8520AEEVEFE42Z	ATK _{ww}	4.20V	SOT-25	- 40°C to +85°C
AME8520AEEVEFE44	ATW _{ww}	4.38V	SOT-25	- 40°C to +85°C
AME8520AEEVEFE44L	ATW _{ww}	4.38V	TSOT-25	- 40°C to +85°C
AME8520AEEVEFE44Y	ATW _{ww}	4.38V	TSOT-25	- 40°C to +85°C
AME8520AEEVEFE44Z	ATW _{ww}	4.38V	SOT-25	- 40°C to +85°C
AME8520AEEVEFE45	ATJ _{ww}	4.50V	SOT-25	- 40°C to +85°C
AME8520AEEVEFE45L	ATJ _{ww}	4.50V	TSOT-25	- 40°C to +85°C
AME8520AEEVEFE45Y	ATJ _{ww}	4.50V	TSOT-25	- 40°C to +85°C
AME8520AEEVEFE45Z	ATJ _{ww}	4.50V	SOT-25	- 40°C to +85°C
AME8520AEEVEFE46	BAD _{ww}	4.63V	SOT-25	- 40°C to +85°C
AME8520AEEVEFE46L	BAD _{ww}	4.63V	TSOT-25	- 40°C to +85°C
AME8520AEEVEFE46Y	BAD _{ww}	4.63V	TSOT-25	- 40°C to +85°C
AME8520AEEVEFE46Z	BAD _{ww}	4.63V	SOT-25	- 40°C to +85°C
AME8530AEEVAFX23Z	CEB _{ww}	2.32V	SOT-25	- 40°C to +85°C
AME8530AEEVAFX29	AVE _{ww}	2.93V	SOT-25	- 40°C to +85°C
AME8530AEEVAFX29L	AVE _{ww}	2.93V	TSOT-25	- 40°C to +85°C
AME8530AEEVAFX29Y	AVE _{ww}	2.93V	TSOT-25	- 40°C to +85°C
AME8530AEEVAFX29Z	AVE _{ww}	2.93V	SOT-25	- 40°C to +85°C
AME8530AEEVAFX31	AVF _{ww}	3.08V	SOT-25	- 40°C to +85°C
AME8530AEEVAFX31L	AVF _{ww}	3.08V	TSOT-25	- 40°C to +85°C
AME8530AEEVAFX31Y	AVF _{ww}	3.08V	TSOT-25	- 40°C to +85°C
AME8530AEEVAFX31Z	AVF _{ww}	3.08V	SOT-25	- 40°C to +85°C
AME8530AEEVEFX26	AWW _{ww}	2.63V	SOT-25	- 40°C to +85°C
AME8530AEEVEFX26L	AWW _{ww}	2.63V	TSOT-25	- 40°C to +85°C
AME8530AEEVEFX26Y	AWW _{ww}	2.63V	TSOT-25	- 40°C to +85°C



AME8510 / 8520 / 8530

Micropower mP Watch Dog Timer

■ Ordering Information

Part Number	Marking*	V _{TH} Voltage	Package	Operating Ambient Temperature Range
AME8530AEEVEFX26Z	AWWww	2.63V	SOT-25	- 40°C to +85°C
AME8530AEEVEFX29	AUSww	2.93V	SOT-25	- 40°C to +85°C
AME8530AEEVEFX29L	AUSww	2.93V	TSOT-25	- 40°C to +85°C
AME8530AEEVEFX29Y	AUSww	2.93V	TSOT-25	- 40°C to +85°C
AME8530AEEVEFX29Z	AUSww	2.93V	SOT-25	- 40°C to +85°C
AME8530AEEVGFX29Z	BKQww	2.93V	SOT-25	- 40°C to +85°C
AME8530AEEVEFX31	ATNww	3.08V	SOT-25	- 40°C to +85°C
AME8530AEEVEFX31L	ATNww	3.08V	TSOT-25	- 40°C to +85°C
AME8530AEEVEFX31Y	ATNww	3.08V	TSOT-25	- 40°C to +85°C
AME8530AEEVEFX31Z	ATNww	3.08V	SOT-25	- 40°C to +85°C
AME8530AEEVEFX45	ATMww	4.50V	SOT-25	- 40°C to +85°C
AME8530AEEVEFX45L	ATMww	4.50V	TSOT-25	- 40°C to +85°C
AME8530AEEVEFX45Y	ATMww	4.50V	TSOT-25	- 40°C to +85°C
AME8530AEEVEFX45Z	ATMww	4.50V	SOT-25	- 40°C to +85°C
AME8530AEEVEFX46	BAEww	4.63V	SOT-25	- 40°C to +85°C
AME8530AEEVEFX46L	BAEww	4.63V	TSOT-25	- 40°C to +85°C
AME8530AEEVEFX46Y	BAEww	4.63V	TSOT-25	- 40°C to +85°C
AME8530AEEVEFX46Z	BAEww	4.63V	SOT-25	- 40°C to +85°C

Note: ww represents the date code and pls refer to Date Code Rule before Package Dimension.

* A line on top of the first letter represents lead free plating such as \overline{A} WYww.

Please consult AME sales office or authorized Rep./Distributor for output voltage and package type availability.

■ Absolute Maximum Ratings

Parameter	Maximum	Unit
Supply Voltage	6	V
ESD Classification	B*	

Caution: Stress above the listed absolute maximum rating may cause permanent damage to the device

* HBM B: 2000V~3999V

■ Recommended Operating Conditions

Parameter	Symbol	Rating	Unit
Ambient Temperature Range	T_A	- 40 to +85	°C
Junction Temperature Range	T_J	- 40 to +125	°C
Storage Temperature Range	T_{STG}	- 65 to +150	°C

■ Thermal Information

Parameter	Package	Die Attach	Symbol	Maximum	Unit
Thermal Resistance* (Junction to Case)	SOT-25 TSOT-25	Conductive Epoxy	θ_{JC}	81	°C / W
Thermal Resistance (Junction to Ambient)			θ_{JA}	260	
Internal Power Dissipation			P_D	400	
Maximum Junction Temperature				150	°C
Solder Iron (10 Sec)**				350	°C

* Measure θ_{JC} on center of molding compound if IC has no tab.

** MIL-STD-202G 210F

■ Electrical Specifications
 $T_A = 25^\circ\text{C}$ unless otherwise noted

Parameter	Symbol	Test Condition	Min	Typ	Max	Units	
V_{IN} Range	V_{RANGE}		1		5.5	V	
Supply Current	I_{IN}	WDI and MRB unconnected		3	10.0	μA	
Reset Threshold*	V_{TH}		V_{TH} -1.5%		V_{TH} +1.5%	V	
ResetB Output Voltage Hgh	V_{OH}	$V_{IN} > V_{TH}$ max	$I_{SOURCE} = 0.5\text{mA}$, $T_J = -40 \sim +85^\circ\text{C}$	0.8 V_{IN}		V	
Reset Output Voltage Hgh		$V_{IN} < V_{TH}$ min					
ResetB Output Voltage Low	V_{OL}	$V_{IN} < V_{TH}$ min	$I_{SNK} = 1.2\text{mA}$, $T_J = -40 \sim +85^\circ\text{C}$		0.5	V	
Reset Output Voltage Low		$V_{IN} > V_{TH}$ max					
V_{IN} to Reset Delay	T_{D1}	$V_{IN} = V_{TH} - 100\text{mV}$		40		μS	
Reset Timeout Period*	T_{D2}	$T_J = -40 \sim +85^\circ\text{C}$	Version D	15	30	50	mS
			Version E	80	150	230	
			Version F	140	210	280	
Watch Dog Timeout Period*	T_{WD}	Version E	1120	1760	2400	mS	
WDI Pulse Width	T_{WDI}		50			nS	
WDI Input Threshold	WDI_{IL}	$V_{IN} = V_{TH} \times 1.2$			0.7	V	
	WDI_{IH}		0.8 V_{IN}			V	
WDI Input Current	I_{IL}	WDI = 0V	-15	-8		μA	
	I_{IH}	WDI = $V_{IN} = 5.0\text{V}$		8	15		
MRB Input Threshold	MRB_{IL}	$V_{IN} = V_{TH} \times 1.2$			0.7	V	
	MRB_{IH}		0.8 V_{IN}				
MRB Pulse Width	T_{WMRB}		1			μS	
MRB Noise Immunity (pulse width with no reset)				100		nS	
MRB to Reset Delay	T_{DMRB}			500		nS	
MRB Pull Up Resistance			80		120	$\text{K}\Omega$	

* See the chart on page 3 for available values of this parameter.

■ Detailed Description

The AME8510/8520/8530 are designed to interface with the reset input of a microprocessor and to prevent CPU execution errors due to power up, power down, and other power supply errors. The AME8510/8520 also monitor the CPU health by checking for signal transitions from the CPU at the WDI input.

Reset Output

Each output pin in the family can be configured to be either push/pull or open drain. In addition each output may be either active high or active low with the condition that parts with two outputs must have opposite polarities. Active high reset outputs are denoted as RESET. Active low reset outputs are denoted as RESETB. The selection guide on page 3 of this data sheet shows all possible combinations of output driver configuration.

A reset will be asserted if any of three things happen:

- 1) V_{IN} drops below the threshold (V_{TH})
- 2) The MRB pin is pulled low.
- 3) The WDI pin does not detect a transition within the watch dog interval (T_{WD}).

The reset will remain asserted for the prescribed reset interval after:

- 1) V_{IN} rises above the threshold (V_{TH})
- 2) MRB goes high
- 3) The watch dog timer has timed out causing the reset to assert.

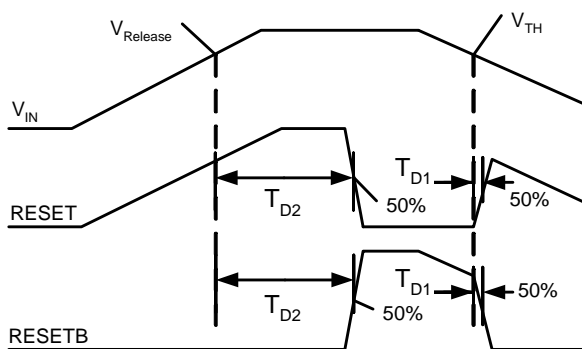

Reset Timing Diagram

Manual Reset Input

The AME8510 and AME8530 feature a manual reset feature (MRB). A logic low on the MRB pin asserts a reset. The reset remains asserted as long as the MRB pin remains low. After the MRB pin transitions to a high state the reset remains asserted for the prescribed reset interval (T_{D2}). The MRB pin is internally pulled up to V_{IN} by a 100K Ω resistor. It is internally debounced to reject switching transients.

The MRB pin is ESD protected by diodes connected to V_{IN} and GND. So the MRB pin should never be driven higher than V_{IN} or lower than GND.

Watchdog Input

The AME8510 and AME8520 are equipped with a watchdog input (WDI). If the microprocessor does not produce a valid logic edge at the the watchdog input (WDI) within the prescribed watchdog interval (T_{WD}) then a reset asserts. The reset remains asserted for the required reset interval (T_{D2}). At the end of the reset interval the reset is deasserted and the watchdog interval timer starts again from zero.

If the watchdog input is left unconnected or is connected to a tri-stated buffer the watchdog function is disabled. As soon as the WDI input is driven either low or high the watchdog function resumes with the watchdog timer set to zero.

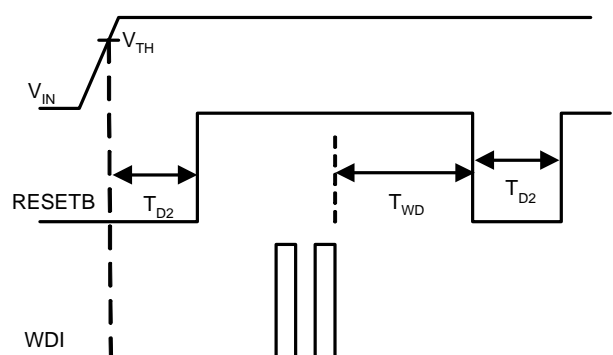

Watchdog Timing Diagram

■ Detailed Description

Watchdog Input Current

The watchdog input pin (WDI) typically sources/sinks $8\mu\text{A}$ when driven high or low. So from a power dissipation point of view the duty cycle of the waveform at WDI is unimportant. When the WDI pin is floating or tri-stated the power supply current falls to less than $3.0\mu\text{A}$.

Glitch Rejection

The AME8510/8520/8530 family will reject negative going transients on the V_{IN} line to some extent. The smaller the duration of the transient the larger its amplitude may be without triggering a reset. The "Glitch Rejection" chart in the graphs section of this datasheet shows the relation between glitch amplitude and allowable glitch duration to avoid unintended resets.

Accurate Output State at Low V_{IN}

With V_{IN} voltage on the order of the MOS transistor threshold ($<1.0\text{V}$) the outputs of the AME8510/8520/8530 may become undefined. For parts with active low output (RESETB) a resistor placed between RESETB and GND on the order of $100\text{K}\Omega$ will ensure that the RESETB output stays low when V_{IN} is lower than the MOS transistor threshold voltage of the part. In a like manner a resistor on the order of $100\text{K}\Omega$ when placed between RESET and V_{IN} will ensure parts with active high output (RESET) will remain high when V_{IN} is lower than the threshold voltage of the part.

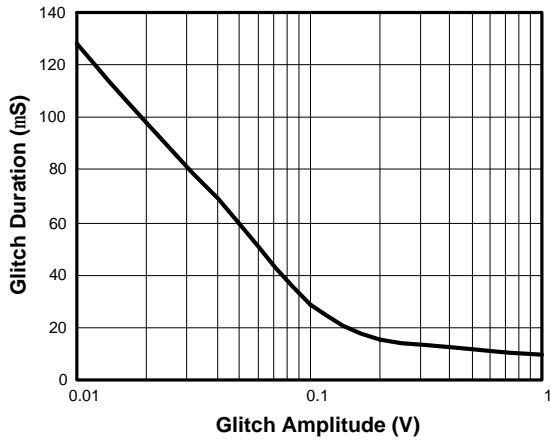
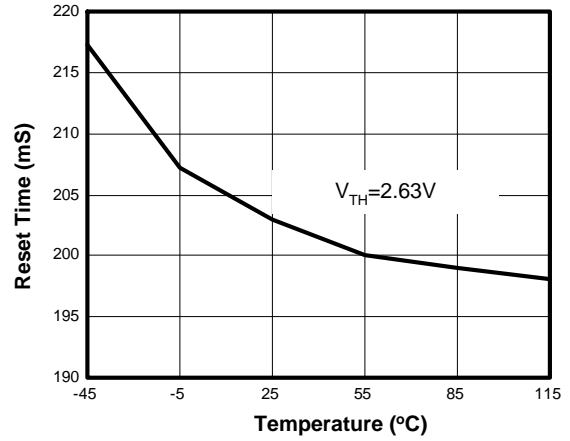
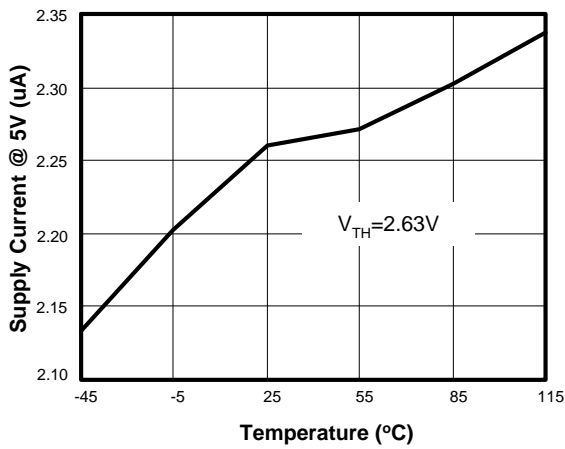
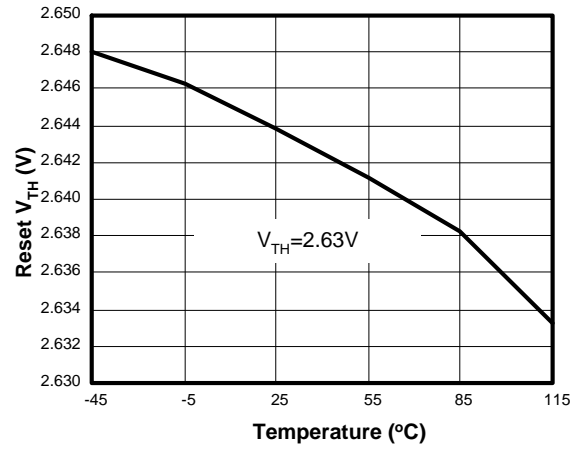
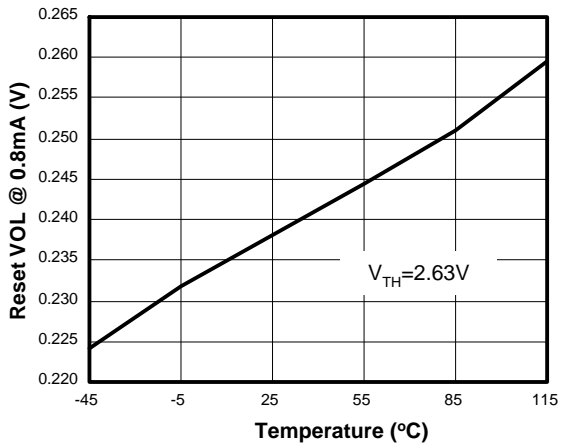
■ Characterization Curve
Glitch Rejection

Reset Time vs. Temperature

I_{IN} vs. Temperature

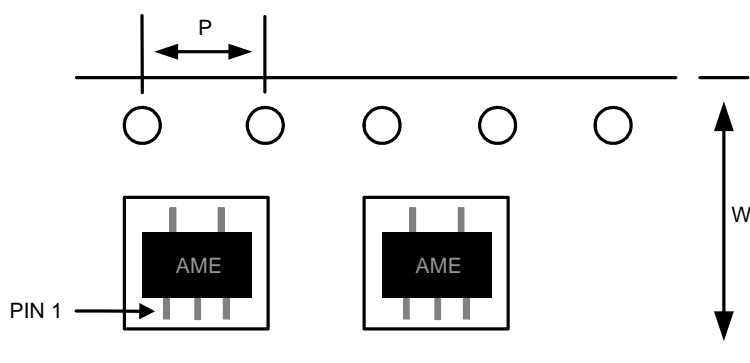
Reset V_{TH} vs. Temperature

Reset VOL vs. Temperature

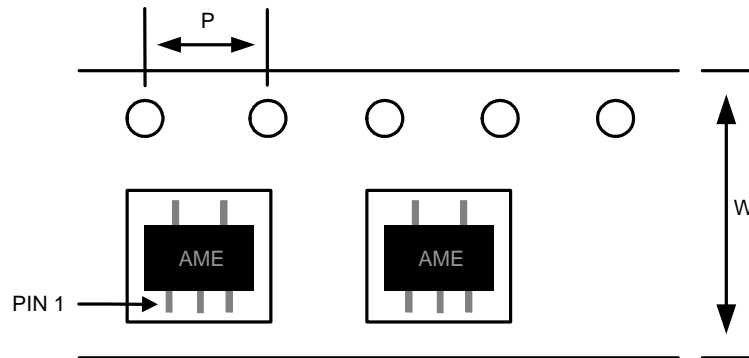
■ Date Code Rule

Marking			Date Code		Year
A	A	A	W	W	xxx0
A	A	A	W	<u>W</u>	xxx1
A	A	A	<u>W</u>	W	xxx2
A	A	A	<u>W</u>	<u>W</u>	xxx3
A	A	<u>A</u>	W	W	xxx4
A	A	<u>A</u>	W	<u>W</u>	xxx5
A	A	<u>A</u>	<u>W</u>	W	xxx6
A	A	<u>A</u>	<u>W</u>	<u>W</u>	xxx7
A	<u>A</u>	A	W	W	xxx8
A	<u>A</u>	A	W	<u>W</u>	xxx9

■ Tape and Reel Dimension
SOT-25

Carrier Tape, Number of Components Per Reel and Reel Size

Package	Carrier Width (W)	Pitch (P)	Part Per Full Reel	Reel Size
SOT-25	8.0±0.1 mm	4.0±0.1 mm	3000pcs	180±1 mm

■ Tape and Reel Dimension
TSOT-25

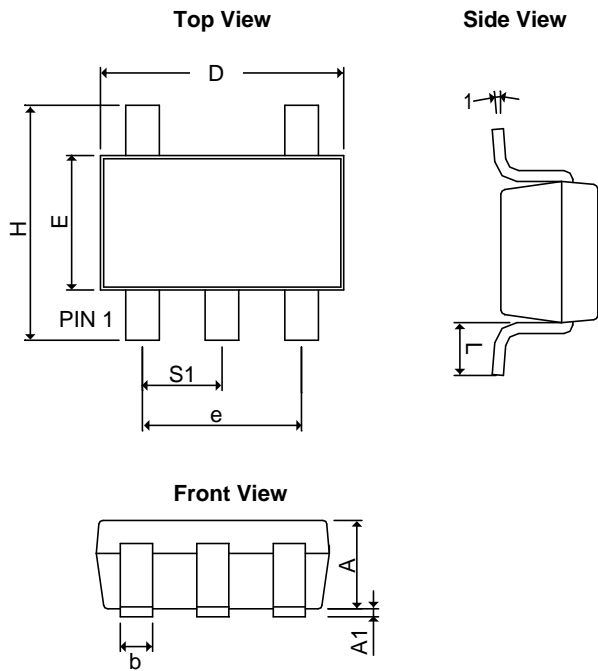
Carrier Tape, Number of Components Per Reel and Reel Size

Package	Carrier Width (W)	Pitch (P)	Part Per Full Reel	Reel Size
TSOT-25	8.0±0.1 mm	4.0±0.1 mm	3000pcs	180±1 mm

■ Package Dimension
SOT-25

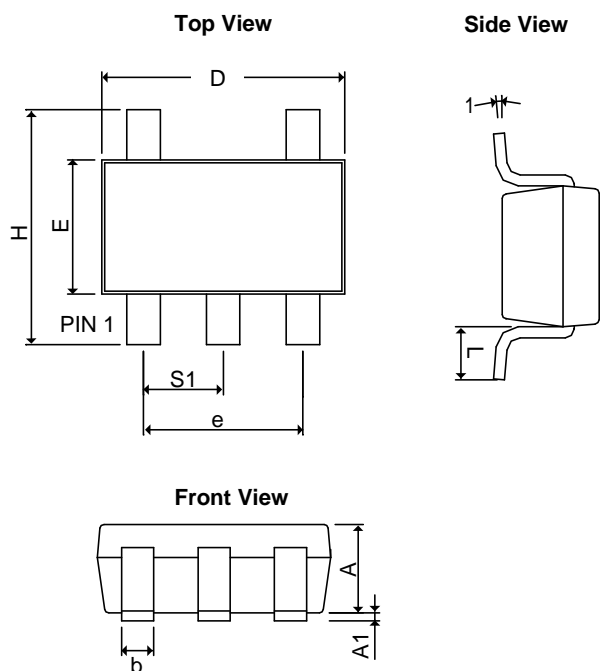
SYMBOLS	MILLIMETERS		INCHES	
	MIN	MAX	MIN	MAX
A	1.20REF		0.0472REF	
A₁	0.00	0.15	0.0000	0.0059
b	0.30	0.55	0.0118	0.0217
D	2.70	3.10	0.1063	0.1220
E	1.40	1.80	0.0551	0.0709
e	1.90 BSC		0.07480 BSC	
H	2.60	3.00	0.10236	0.11811
L	0.37BSC		0.0146BSC	
q1	0°	10°	0°	10°
S₁	0.95BSC		0.0374BSC	

TSOT-25

SYMBOLS	MILLIMETERS		INCHES	
	MIN	MAX	MIN	MAX
A+A₁	0.90	1.25	0.0354	0.0492
b	0.30	0.50	0.0118	0.0197
c	0.09	0.25	0.0035	0.0098
D	2.70	3.10	0.1063	0.1220
E	1.40	1.80	0.0551	0.0709
e	1.90 BSC		0.07480 BSC	
H	2.40	3.00	0.09449	0.11811
L	0.35BSC		0.0138BSC	
q1	0°	10°	0°	10°
S₁	0.95BSC		0.0374BSC	



www.ame.com.tw
E-Mail: sales@ame.com.tw

Life Support Policy:

These products of AME, Inc. are not authorized for use as critical components in life-support devices or systems, without the express written approval of the president of AME, Inc.

AME, Inc. reserves the right to make changes in the circuitry and specifications of its devices and advises its customers to obtain the latest version of relevant information.

© AME, Inc. , July 2011

Document: 2007-DS8510/8520/8530-1.09

Corporate Headquarter
AME, Inc.

2F, 302 Rui-Guang Road, Nei-Hu District

Taipei 114, Taiwan.

Tel: 886 2 2627-8687

Fax: 886 2 2659-2989